

ACCLAIM LED FRESNEL

Date: _____
Type: _____
Firm: _____
Name: _____
Project: _____

The Strand Acclaim LED Fresnel is a full color theatrical Fresnel wash fixture designed specifically for small to medium spaces. The Acclaim has set the standard in 500 W/650 W lighting for a generation, and this new LED version offers saturated stage color washes and dramatic highlighting capabilities thanks to the high quality, industry standard 4.75" front lens coupled with the engineering excellence that has set Strand apart for over a century. A true theatrical Fresnel, the Acclaim LED Fresnel offers superior control and light quality to comparable PAR fixtures. The adjustable 10° to 40° zoom provides manual adjustment with minimal light scatter, and the even, soft-edged beam easily blends with adjacent fixtures without hard edges to soften with frost filters or hot spots to smooth out in the beam. To shape the beam, users can add an optional rotating four leaf barndoor that mounts on the front of the fixture and rotates around the axis for the perfect angle. The Acclaim LED Fresnel is available in black or white.



- 500 W/650 W-equivalent LED Fresnel – true Fresnel with superior control and light quality than comparable PAR fixtures.
- Built with the DNA of Strand - cost-effective luminaire from the original name in theatrical lighting.
- Integrated 10° to 50° manual zoom – precise beam sizing with minimal light scatter.
- Optional rotating 4-leaf barn doors – shape the beam to focus light where you need it.
- Custom LED light source and RGBL color mixing system – consistent output and color mixing with the entire Acclaim LED Series.
- Available in black or white – the perfect body color for your application.

For detailed product information, please refer to www.strandlighting.com/global/products/acclaim-led-fresnel



 **Strand**

Specifications

Due to continuous improvements and innovations, specifications may change without notice.

Source

LED	Multichromatic Light Engine - RGBL
Source Max Power Consumption	150 W
LED Refresh Rate	500 Hz to 4000 Hz
Dimming	Electronic 8-bit / 16-bit
Dimmer Curves	Square Law (Default), Linear, S -Curve
Dimmer Control Option	Dimmer Snap On/Off On reduces auto dimmer smoothing
Tungsten Fade	Selectable on/off
Strobe	Electronic
Strobe Speed	0 - 30Hz
Strobe Modes	Standard, Lightening, Random

Optical Performance

Zoom Range	10 - 50°
Zoom Control	Manual control
Output Lumens	Beam - 4,500, Field - 8500
Lens Size	125 mm (5 in)
CRI RA	7100 K - 85 5600 K - 84 3200 K - 80
Tm30	7100 K - Rf 81 / Rg 102 5600 K - Rf 81 / Rg 102 5600 K - Rf 81 / Rg 102
CQS	7100 K - 80 5600 K - 79 3200 K - 71
TLCI	7100 K - 80 5600 K - 79 3200 K - 74

Color System

Color Mixing	RGBL
Color Mixing Control	Open Source
Color Calibration	Selectable On/Off
Color Mixing Control Option	Color Snap On/Off On reduces auto smoothing color to create faster color changes

Electrical

Output Power Consumption	170 W
Power Connection	TrueOne Compatible - In / Thru Power cable not included - input connector only
Input Voltage	100-240 VAC, 50 / 60 Hz
Standby Power	8.8 W

Data

Supported Protocols	DMX512-A (RDM) 5 - Pin XLR Input and Thru
DMX Modes	
16-Bit	11 Channels
8-Bit	8 Channels

Noise Level / Fan Control (Base Level 21 dB @ 1 m (3.3 ft))

Standard Mode	42.6 dB
Studio Mode	37 dB
Whisper Mode	33.2 dB
Fan Mode	Continuous (On) / Auto Ramping
Fan Level Preset	Standard, Studio, Whisper
Cooling System Type	Forced Air Cooling

Mounting

Yoke	Double clutch locking yoke >270° Swivel Yoke M12 (1/2") Centre hole
------	--

Certification and Safety

Approbations	ETL (UL & CSA)CB/IECEE Scheme for CE-LVD, FCC, ICES, RCM, CE-EMC, UKCA, RoHS, ISO 9001
IP Rating	IP20

Photometrics and IES Files

For IES files and photometric reports, please refer to the product page: www.strandlighting.com/global/products/acclaim-led-fresnel

Dimensions

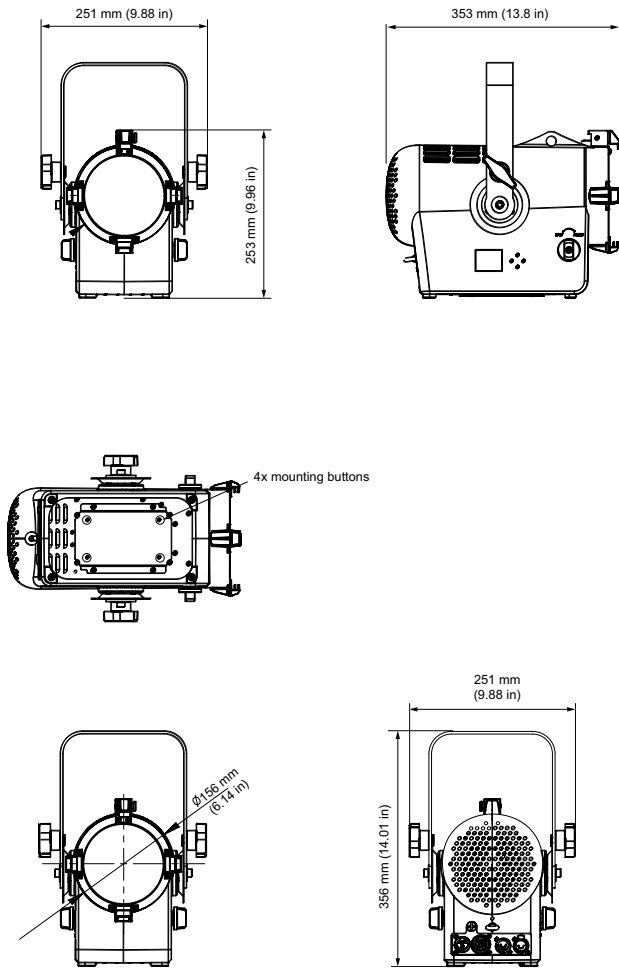

Physical

Construction	Machined aluminum, sheet metal, and molded engineering grade plastic components
Standard Finish	Black, White
Dimensions	190 x 253 x 353 mm (7.5 x 10.0 x 13.8 in)
Dimension (w/ yoke)	356 x 251 x 353 mm (14.0 x 9.8 x 13.8 in)
Fixture Weight	5.8 kg (12.8 lb)
Operating Temperature	-10-40°C (14-104°F)

Luminaire and Accessories

Product type	Order Code
ACCLAIM LED FRESNEL, Black	64511-001
ACCLAIM LED FRESNEL, 150W Multichromatic Light Engine - RGBL, c/w Gel Frame & Power input connector, Black	
ACCLAIM LED FRESNEL, White	64511-101
ACCLAIM LED FRESNEL, 150W Multichromatic Light Engine - RGBL, c/w Power input connector, White	
Accessories	
Acclaim LED barndoor (Black)	64511-011
ACCLAIM LED ZOOMSPOT, Accessory Holder, Black	
Acclaim LED barndoor (White Outer)	64511-110
ACCLAIM LED FRESNEL, Barndoor - 4 Leaf , White Outer	

