

MAC ONE

CREATIVE BEAMWASH MOVING HEAD WITH FRESNEL LENS

SPEC SHEET



Setting a new standard for compact moving heads, **MAC One** is a revolutionary Beam, Wash and Eye-Candy fixture, featuring a captivating Fresnel lens that transforms any stage or event into an extraordinary visual spectacle. Compact, lightweight, and highly versatile, MAC One defines a new compact class of performance lighting.

MAC One excels in three powerful feature areas. First, its narrow, high-intensity beam packs the same punch as larger, heavier fixtures to enable robust and vibrant aerial effects. Next, its stunning Fresnel lens creates a soft wash with a wide 4 to 27-degree zoom range, delivering seamless transitions and engaging visual effects. Rounding out the robust feature-set is an innovative backlight system with 24 RGB effect LEDs within the lens to guarantee memorable and show-stopping visual experiences.

With an impressive output of 2,400 lm and a narrow beam intensity of 300,000 cd, MAC One's performance is unparalleled in its category. Powered by a custom-developed 120 W RGBL (Red, Green, Blue, Lime) LED engine, it ensures higher light quality (CRI, TM-30, TLCI) than traditional RGBW fixtures, appealing to discerning lighting designers.

MAC One stands out against competing fixtures by delivering an innovative combination of features in an incredibly compact and low-weight form-factor. The fixture is easy to handle and manage, opening up a world of creative possibilities for lighting designers and users. More fixtures can be used in a show without compromising weight or space limitations, resulting in lower transport costs and a significant return on investment for rental companies.

For additional versatility, MAC One can also be used with the interlocking accessory system originally created for Martin's VDO Atomic products. Martin fourbar and matrix accessories can also be used to further extend its design potential and ease large quantity deployment. MAC One can be driven with DMX, Art-Net, sACN, and Martin P3 control systems for seamless integration into any lighting setup.

Whether you are a lighting designer, rental company, or event organizer, MAC One is the answer for creating big looks with many fixtures, utilizing a compact fixture for tight spaces or enthralling the stage with captivating eye-candy effects. Transcend expectations, empower creative expression and revolutionize the stage with MAC One.



COMPACT & LIGHTWEIGHT
Easy to move and install



NARROW FAST BEAM
Very impressive and snappy beams

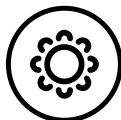

BEAUTIFUL BACKLIGHT
Unique eye-candy looks from Fresnel Lens and backlight effect



FRESNEL WASH
Compact wash light that fits everywhere

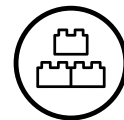

SCALABLE
Easy to deploy in large quantities using smart rigging accessories

MAC ONE

CREATIVE BEAMWASH MOVING HEAD WITH FRESNEL LENS

SPEC SHEET

FEATURE HIGHLIGHTS

A PUNCH ABOVE + WELL DEFINED INTENSITY

With 2,400 lm output from a form factor just above 4kg, MAC One features great output to size ratio, delivering impressive light output from a compact and lightweight fixture. Additionally, MAC One's narrow beam intensity of 300,000 cd ensures a well-defined, tight, fast, and responsive mid-air beam.

HIGH QUALITY LIGHT OUTPUT

Martin's custom-designed 120 W RGBL (Red, Green, Blue, Lime) LED engine with higher CRI / TM-30 / TLCI offers better rendering of people and costumes for demanding broadcast and theater applications.

BEAUTIFUL TO LOOK AT, BEAUTIFUL TO LIGHT UP

MAC One offers precision control for the most demanding applications in broadcast and theatre and the ability to remove unwanted flicker in broadcast applications. It also offers beautiful eye-candy, empowering it to decorate the stage when the fixture is not being used as a beam or wash.

BEAMING BRILLIANCE

With a 4 to 27 degree zoom, MAC One can deliver a tight, fast, and well-defined beam, but also a soft-edged wash with its championed Fresnel lens, often loved by lighting designers.

EXTREMELY COMPACT SIZE

Weighing just 4.4 kg / 9.7 lbs., MAC One is easy to deploy in large quantities and reduces shipping costs and environmental impact. It's also perfect for venues with load-bearing limits or space-constraints.

ACCESSORY ADAPTATIONS

With the optional fourbar accessory, MAC One fixtures can be transported, rigged, unrigged, and cabled in blocks of four, saving time when deploying several fixtures. An optional grid mount adapter enables the fixtures to be rigged in (self-supported) lines and matrices for creation of a 'wall of light' without needing a custom rigging structure. Lines and matrices can contain a mix of MAC One and VDO Atomic Bold and Dot fixtures.

FEATURES

Light Source

- Light Engine: Custom in-house developed 120 W RGBL (Red, Green, Blue, Lime) LED offering higher light quality (CRI, TM-30, TLCI) than RGBW.
- Lumen Output: 2400 lm
- Intensity: 300,000 cd in narrow beam

Optics

- Zoom: 4 to 27 degrees zoom
- 150 mm Fresnel lens
- 24 RGB backlight LEDs

Construction

- Weight: 4.4 kg / 9.7 lbs.
- Weather rating: IP20-rated

Control

- DMX, Art-Net, sACN & Martin P3 control.
- Battery-powered display for setup and configuration.

Installation

- Single omega bracket attachment
- M12 threaded holes for direct clamp attachment or attachment to four-bar accessory
- Optional four-bar accessory.
- Optional grid mount ring accessory.



MAC ONE

CREATIVE BEAMWASH MOVING HEAD WITH FRESNEL LENS

SPEC SHEET

ORDERING INFORMATION

MAC One in Cardboard (in cardboard box with cardboard inlay):
P/N MAR-90250200HU

MAC One in dual SiP (in cardboard box with dual SiP foam flight case insert): P/N MAR-90250205HU (to be ordered in multiples of 2)

MAC One white in Cardboard (in cardboard box with cardboard inlay):
P/N MAR-90250210HU

INCLUDED ITEMS

- Single omega bracket with 1/4 turn fasteners for rigging clamp attachment
- SoftLens
- Multi-Language Safety and Installation Manual

RELATED ITEMS

- VDO Atomic Bold in cardboard: P/N MAR-90357703
- VDO Atomic Dot CLD in cardboard: P/N 90357701
- VDO Atomic Dot WRM in cardboard: P/N 90357702
- Martin Companion Cable (for firmware update over DMX): P/N 91616091
- Martin Companion Software (for firmware update over DMX/Ethernet): Free download from martin.com

ACCESSORIES

TRANSPORT AND STORAGE

- Flightcase for 8 x MAC OneP/N MAR-91515058
- Additional dual SiP Foam Flightcase
Insert for MAC One P/N MAR-91611862HU

CONSUMABLES

- CR123A 3-volt lithium battery..... P/N 05801011

SPARE PARTS

- Additional MAC One SoftLens.....P/N 5137039-00

POWER INPUT CABLES

- Power Input Cable, H07Rn-F, 2.5 mm²,
bare ends to TRUE1 NAC3FX-W TOP (female),
1.5 m (4.9 ft.) P/N 91611797
- Power Input Cable, SJOOW, 12 AWG, bare
ends to TRUE1 NAC3FX-W TOP (female),
1.5 m (4.9 ft.) P/N 91610173

POWER LINKING CABLES

- Power relay cable, H07RN-F, 2.5 mm²,
TRUE1 to TRUE 1, 2.5 m (8.2 ft.) P/N 91611796
- Power relay cable, SJOOW, 12 AWG,
TRUE1 to TRUE 1, 2.5 m (8.2 ft.) P/N 91610172

POWER CONNECTORS

- Cable Connector, Neutrik powerCON
TRUE1 TOP Female P/N 91611789HU
- Cable Connector, Neutrik PowerCON
TRUE1 TOP Male P/N 91611788HU

PDE ADAPTER CABLES (for use in matrix with VDO Atomic Bold/Dot)

- BreakIn Cable
Power-DMX-Ethernet to PDEP/N MAR-91700000
- BreakOut Cable
PDE to Power-DMX-Ethernet P/N MAR-91700001

INSTALLATION HARDWARE

- MAC One Fourbar P/N MAR-91616127HU
- MAC One Grid Mount Ring P/N MAR-91616128HU
- Set of 10 VDO Couplers P/N MAR-91616129HU
- VDO Coupler Header P/N MAR-91616130HU
- VDO Atomic Half Coupler P/N 91610004
- VDO Atomic Interlock Adapter P/N 91610006
- G-clamp (suspension with fixture
hanging vertically downwards only)..... P/N 91602003
- Quick Trigger Clamp (suspension with
fixture hanging vertically downwards only) P/N 91602007
- Half-coupler Clamp..... P/N 91602005
- Safety Cable, SWL 60 kg,
BGV C1 / DGUV 17, black..... P/N 91604006
- Safety Cable, SWL 60 kg,
BGV C1 / DGUV 17, silver..... P/N 91604007

MAC ONE

CREATIVE BEAMWASH MOVING HEAD WITH FRESNEL LENS

SPEC SHEET

TECHNICAL SPECIFICATIONS

DYNAMIC EFFECTS

Beam Dimmer/Shutter	0-100% continuous dimming, regular and random strobe, instant open and blackout
Beam Dimming options	Choice of four dimming curves
Beam Color Mixing	RGB, independently variable 0-100%
Beam Color Temperature Control	Variable 1,000-12,850 K
Beam Tint Control	Variable green-magenta shift Δuv -0.05 - +0.05
Beam Virtual Color Wheel	48 color presets, continuous rotation & random color
Zoom	Motorized with 1:5 ratio, including zoom pulse effect
Pan	Motorized 540°
Tilt	Motorized 240°
Beam P3 Mix	Videomapping of fixture with variable crossfade between DMX control and video control
Backlight Dimmer/Shutter	0-100% continuous dimming, regular and random strobe, instant open and blackout
Backlight Dimming options	Choice of four dimming curves
Backlight Color Mixing	RGB, independently variable 0-100%
Backlight Color Temperature Control	Variable 1,000-12,850 K
Backlight Tint Control	Variable green-magenta shift Δuv -0.05 - +0.05
Backlight Virtual Color Wheel	48 color presets, continuous rotation & random color
Backlight Pixelmapping	Individual RGB control of each of the 24 Backlight panels
Backlight P3 Mix	Videomapping of fixture with variable crossfade between DMX control and video control
Pre-programmed effects	Two ranges of FX on Beam, Backlight or Combination; independent or synchronized/combined
LED Frequency control	Variable LED PWM control

CONTROL AND PROGRAMMING

Control Protocols	DMX, RDM, Art-Net, RDM over Art-Net, sACN and P3
Protocol Detection	Automatic
DMX Modes	Compact, Basic, Ludicrous & Compact Direct
DMX Channels	20, 36, 108 & 20
16-bit Controllable Parameters	Beam & Backlight Dimming, Beam Color Mixing, Zoom, Pan and Tilt
Setting and Addressing	Display Menu, RDM, RDM over Art-Net or P3
Local User Interface	Backlit LCD Display with battery-powered operation
Fixture identification	User-settable ID number
DMX Compliance	USITT DMX512-A
RDM Compliance	ANSI/ESTA E1.20
Art-Net Compliance	Art-Net 1, 2, 3 and 4; including RDM over Art-Net

sACN Compliance	ANSI E1.31 - 2016
Martin P3 Compliance	P3 System Controller Software 5.1.0 or newer
DMX/RDM Transceiver	Galvanic-isolated RS-485
Ethernet Transceiver	10/100Mbit (with fail-safe bypass)
Firmware Update	via DMX using Martin Companion or via Ethernet using Martin Companion / P3 System Controller

OPTICS

Front Lens Diameter	150 mm (5.91 in.)
Zoom range	1:5
Full Zoom Range at Half Peak (Beam Angle)	4.0° - 21.0°
Full Zoom Range at Tenth Peak (Field Angle)	6.0° - 27.0°
Beam Light Source	1 x 120 W RGB LED
Backlight Light Source	24 x 0.25 W RGB LED
Max. Total Beam LED Engine Power	120 W
Max. Total Backlight LED Engine Power	6 W
Minimum LED Lifetime	> 50,000 hours (to > 70% luminous output)*

*Figure obtained under manufacturer's test conditions

PHOTOMETRIC DATA

Light Engine Luminous Output	5,680 lumens
Fixture Luminous Output Wide	2,400 lumens
Fixture Luminous Output Narrow	1,800 lumens
Peak Luminous Intensity Narrow	300,000 cd
CCT	Variable 1,000 K - 12,850 K (+/- 200 K)
CRI (Color Rendering Index)	
High Output Mode	≥ 77
High Quality Mode	≥ 83
CQS (Color Quality Scale)	
High Output Mode	≥ 87
High Quality Mode	≥ 90
TM-30 Rf (IES TM-30-15 Fidelity Index)	
High Output Mode	≥ 81
High Quality Mode	≥ 84
TM-30 Rg (IES TM-30-15 Gamut Index)	
High Output Mode	≥ 114
High Quality Mode	≥ 110
TLCI (Television Lighting Consistency Index)	
High Output Mode	≥ 70
High Quality Mode	≥ 84
Beam LED Refresh Rate	2,400 Hz with adjustment (+/- 2%) via DMX
Backlight LED Refresh Rate	1,200 Hz
Binning	Tight color and flux binning
Calibration	Full Gamut Color Calibration of Beam and Backlight

MAC ONE

CREATIVE BEAMWASH MOVING HEAD WITH FRESNEL LENS

SPEC SHEET

TECHNICAL SPECIFICATIONS

PHOTOMETRIC DATA (Cont.)

Color Modes Extended Color Mode and Calibrated Color Mode

**All Photometric Data measured in steady state (30 minutes warm-up time) at 25°C ambient.*

CONSTRUCTION

Housing High-impact flame-retardant thermoplastic

Color Black

Protection rating IP20

INSTALLATION

Mounting options Clamps on fixture, omega on fixture, fourbar or grid mount ring

Mounting points on fixture 1 pair of 1/4-turn points for 106 mm (4.17 in.) center-to-center omega bracket and two M12 threaded holes

Mounting points on fourbar 1 fixed and 2 repositionable M12 threaded holes

Mounting points on grid mount ring 6 receivers for VDO couplers (compatible with VDO Atomic Bold/Dot)

Mounting points on VDO coupler header 2 repositionable M12 threaded holes and 4 receivers for VDO couplers (compatible with grid mount ring and VDO Atomic Bold/Dot)

Maximum vertical column height in grid mount rings 6 fixtures

Location Indoor or outdoor protected from elements

Orientation Any

Minimum distance to combustible materials 0.20 m (7.87 in.)

Minimum distance to illuminated surfaces 1.75 m (68.90 in.)

CONNECTIONS

AC mains power in/thru Neutrik powerCON TRUE1 TOP

DMX and RDM data in/thru Neutrik 5-pin locking XLR

Ethernet (Art-Net, sACN and P3) in/thru, including fail-safe bypass Neutrik etherCON

ELECTRICAL

AC power 100-240 V AC nominal, 50/60 Hz

Power supply unit Auto-ranging electronic switch mode

Typical half-cycle RMS inrush current at 230 V, 50 Hz 3.5 A

Typical earth-leakage current 0.05 mA

Power Factor 0.99 @ 100 V, 0.98 @ 120 V, 0.94 @ 208 V, 0.92 @ 230 V, 0.88 @ 240 V

Max current draw 2.0 A @ 100 V / 120 V, 0.9 A @ 208 V / 230 V / 240 V

Typical current draw 1.6 A @ 100 V, 1.4 A @ 120 V, 0.9 A @ 208 V, 0.8 A @ 230 V, 0.8 A @ 240 V*

Power Consumption

Maximum 180 W

Typical 160 W*

Idle 24 W*

Hibernation 9 W*

**Measurements made at nominal voltage. Allow for a deviation of +/- 10%.*

Typical: full output white, no effects moving, regulated fan speed.

Idle: no output, no effects moving, regulated fan speed.

Hibernation: no output, motors de-energized, fans stopped, wake-up procedure to re-use fixture.

THERMAL

Cooling Forced air (temperature regulated, low noise, user-definable levels)

Max. ambient temperature (Ta max.) 40° C (104° F)

Min. ambient temperature (Ta min.) 5° C (41° F)

Max. surface temperature, steady state, at 40° C ambient 55° C (131° F)

Total heat dissipation (calculated +/- 10%) 546 BTU/hr.

ACOUSTIC DATA

Sound Pressure Level (LpA) @ 1m (default regulated fan mode, full output) 32.6 dB(A)

Sound Pressure Level (LpA) @ 1 m (constant fan mode ultra low) 24.6 dB(A)

ENVIRONMENTAL

RoHS Compliant

REACH Compliant

WEEE Compliant

Proposition 65 Compliant

FSC Certified cardboard inner and outer packaging

Efficacy (max output) 15 lm/W

LWR (Lumen-to-Weight Ratio) 545 lm/kg (247 lm/lbs.)

APPROVALS

Global CB Certification/IECEE IEC 60598-2-17 (IEC 60598-1)

EU safety EN 60598-2-17 (EN 60598-1), EN 62471, EN 62493

EU EMC EN 55015; EN 55032; EN 55035; EN 61547; EN 61000-3-3

US safety UL 1573

US EMC FCC Part 15 Class B

Canadian safety CSA C22.2 No. 166

Canadian EMC ICES-003 Class B, ICES-005 Class B

Australia/NZ RCM

United Kingdom UKCA



MAC ONE

CREATIVE BEAMWASH MOVING HEAD WITH FRESNEL LENS

SPEC SHEET

DIMENSIONS

PHYSICAL

Width (across yoke) 226 mm (8.90 in.)
Width (base) 254 mm (10.00 in.)
Height (head straight up)..... 336 mm (13.23 in.)
Height (maximum)..... 349 mm (13.74 in.)

Depth (head) 220 mm (8.66 in.)
Depth (base) 177 mm (6.97 in.)
Min. center-to-center distance in
side-by-side installation 300 mm (11.81 in.)
Weight 4.40 kg (9.70 lbs.)

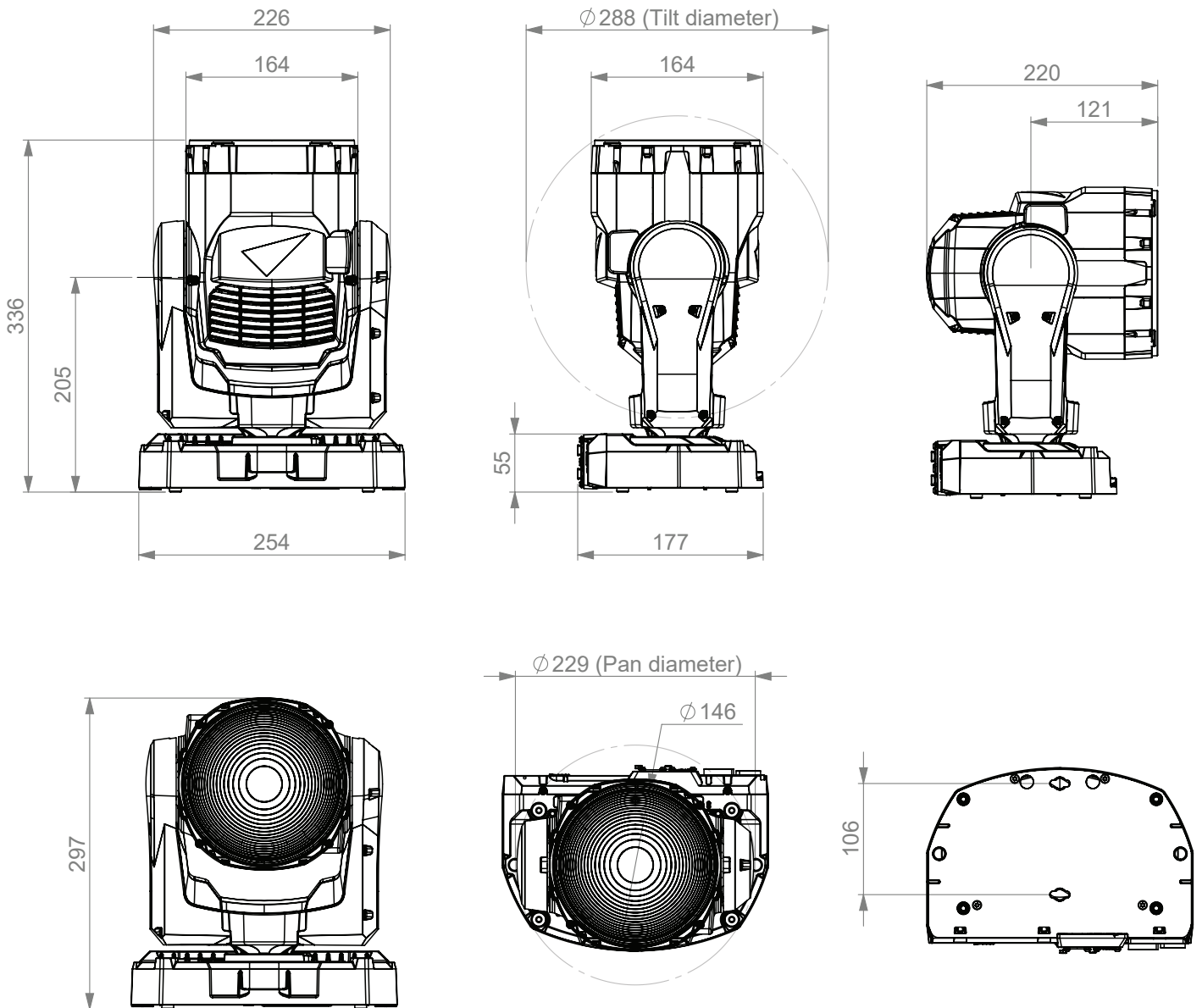

All dimensions are in mm