



# ReLite Led Kit 250 VariWhite

**Provisional**

## KEY FEATURES

- 2.700 - 6.500 K continuously variable CCT
- CRI  $\geq$  95 (up to 97)
- Linear dimming from 1% to 100% via DMX
- Flicker-free ideal for TV/Broadcast installations
- No color-shift with dimming
- Huge power savings (reduce your power consumption by over 90%)  
with almost no heat generated
- No heat on your subject



## SPECIFICATIONS

- CCT proportional control from 2.700 to 6.500 K
- Linear dimming from 1% to 100% via DMX
- No color shifts during dimming
- Flicker-free operation with LEDs frequency controlled via DMX or display from 640 to 1.500 Hz (different curves selectable)
- Operating Ta range (°C/F): from -20° to +45°C (from -4° to +113° F)  
thermal protection at 65°C/149°F
- IP rating: 20
- Instantly upgrade an existing Arri, ADB or De Sisti (and more)

## LIGHT SOURCE

- Modular multiple LEDs (CRI  $\geq$  95 up to 97)
- Average LED lifetime: a minimum of 80% of the initial luminous flux will be maintained after approx. 50.000 hours of usage (50.000 LM80)

## PHYSICAL SIZE (BOX)

- Length: 210 mm (8.26 in)
- Width: 124 mm (4.88 in)
- Height: 90 mm (3.54 in)
- Weight: 2.5 Kg (5.5 lbs )

## CONTROL PROTOCOL AND PROGRAMMING

- USITT DMX512A
- DMX channels: 6 / 2 / 1
- Setting, addressing, testing and measurements via LEDs display
- RDM (Remote Device Management)

## ELECTRICAL SPECIFICATIONS AND CONNECTIONS

- Power supply: 90-240 V, auto-sensing, 50/60 Hz
- In and Out PowerCon connectors
- Power consumption: depending on the LED module and the size/model of the fixture
- DMX data in/out: 5 pin locking XLR
- Pin connectors: GX9.5, G22 (other pin available on request)

## DRAWING SIZE

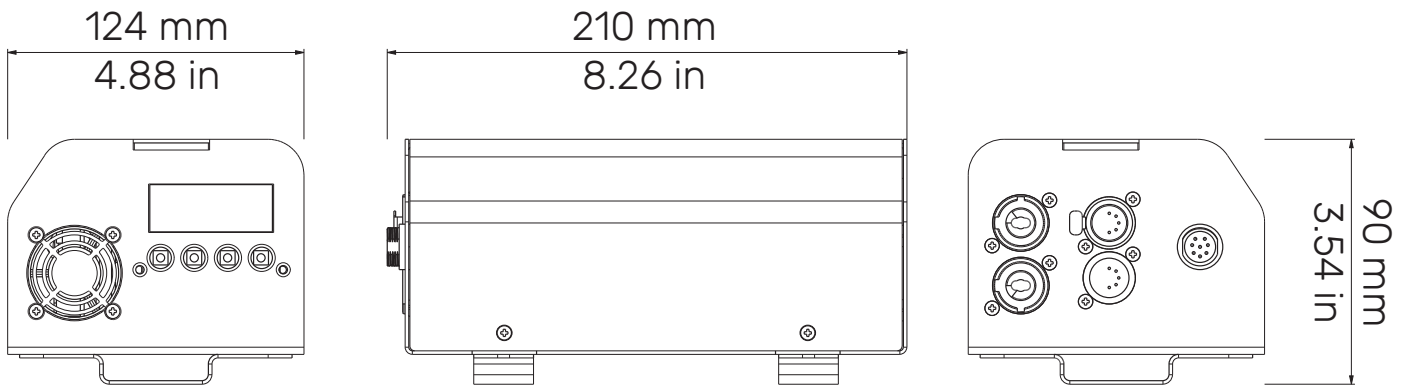

## DMX CHARTS

6 channels	
1	master dimmer
2	dimmer fine
3	white tone
4	white fine tuning
5	strobe effect
6	special function

2 channels	
1	master dimmer
2	white tone

1 channel	
1	master dimmer