



# ReLite Led Kit 150 VariWhite

## KEY FEATURES

- 2.700 - 6.500 K continuously variable CCT
- CRI  $\geq$  95 (up to 97)
- Linear dimming from 1% to 100% via DMX
- Flicker-free ideal for TV/Broadcast installations
- No color-shift with dimming
- Huge power savings (reduce your power consumption by over 90%)  
with almost no heat generated
- No heat on your subject



## SPECIFICATIONS

- CCT proportional control from 2.700 to 6.500 K
- Linear dimming from 1% to 100% via DMX
- No color shifts during dimming
- Flicker-free operation with LEDs frequency controlled via DMX or display from 640 to 1.500 Hz (different curves selectable)
- Operating Ta range (°C/F): from -20° to +45°C (from -4° to +113° F)  
thermal protection at 65°C/149°F
- IP rating: 20
- Instantly upgrade an existing Arri, ADB or De Sisti (and more)

## LIGHT SOURCE

- Modular multiple LEDs (CRI  $\geq$  95 up to 97)
- Average LED lifetime: a minimum of 80% of the initial luminous flux will be maintained after approx. 50.000 hours of usage (50.000 LM80)

## PHYSICAL SIZE (BOX)

- Length: 190 mm (7.48 in)
- Width: 110 mm (4.33 in)
- Height: 73 mm (2.87 in)
- Weight: 1.5 Kg (3.31 lbs)

## CONTROL PROTOCOL AND PROGRAMMING

- USITT DMX512A
- DMX channels: 6 / 2 / 1
- Setting, addressing, testing and measurements via LEDs display
- RDM (Remote Device Management)

## ELECTRICAL SPECIFICATIONS AND CONNECTIONS

- Power supply: 90-240 V, auto-sensing, 50/60 Hz
- In and Out PowerCon connectors
- Power consumption: depending on the LED module and the size/model of the fixture
- DMX data in/out: 5 pin locking XLR

## DRAWING SIZE

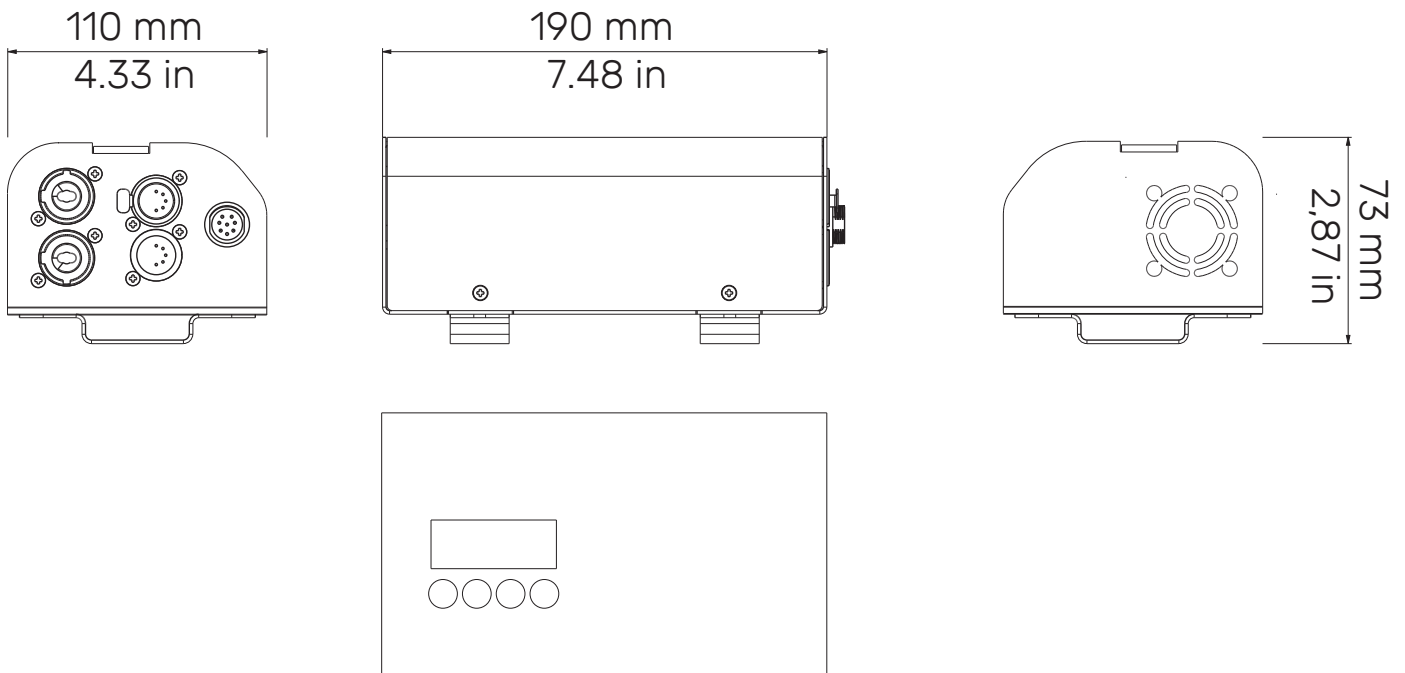

## DMX CHARTS

| 6 channels |                   |
|------------|-------------------|
| 1          | master dimmer     |
| 2          | dimmer fine       |
| 3          | white tone        |
| 4          | white fine tuning |
| 5          | strobe effect     |
| 6          | special function  |

| 2 channels |               |
|------------|---------------|
| 1          | master dimmer |
| 2          | white tone    |

| 1 channel |               |
|-----------|---------------|
| 1         | master dimmer |