

EURUS

an uncompromising synthesis



AYRTON

Digital Lighting



Eurus an uncompromising synthesis

Eurus is an unusually versatile machine that spans the spectrum of applications that you'll need most often. A machine that offers complete diversity of use, with no compromise on quality.

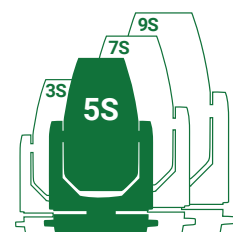

What kind of luminaire do you really need? A luminaire that is: powerful and compact? Elegant and robust? Perfect for stage and studio applications? One that is lightweight and silent? Monochromatic or colour-rich? Precise, in order to satisfy your creativity

As a matter of fact, what you really need is Eurus - an uncompromising synthesis.

Eurus is an unusually versatile machine that spans the spectrum of applications that you'll need most often. A machine that offers complete diversity of use, with no compromise on quality. A new addition to the 5 Series, Eurus is the first multi-function profile luminaire launched under the new SLIM-21 programme for miniaturising fixtures and reducing their weight.

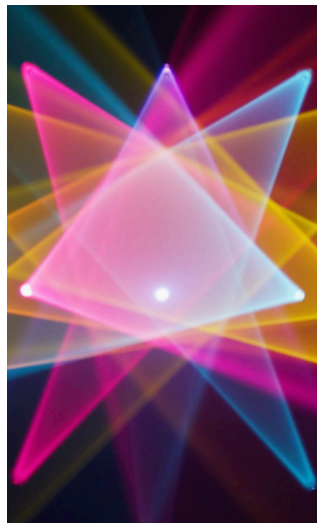
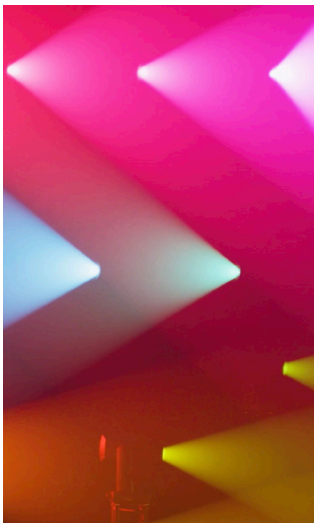

Eurus is the synthesis of all that you need

A marvel of technology that incorporates a 170 mm frontal lens producing an intensive 4.5° beam in a highly compact product format. A lighting profile that can be easily used for both short and long-range applications.

AYRTON has developed a high-efficiency power supply in an entirely new die-cast aluminium base that takes up 33% less volume than in other luminaires of the same category. A lighter internal structure and all-new miniaturised stepper motors add to its excellence.



33% less volume
than in other luminaires



Eurus is a powerhouse of performance

Eurus, is available in two versions: S and TC.

Eurus-S, specially designed for stage applications, is equipped with a new 650-Watt ultra-compact monochromatic LED emitter calibrated at 8000 Kelvin. It can deliver metallic white light with an output of 32,000 lumens at a colour temperature of 6700 Kelvin.

Eurus-TC is geared for applications that require perfect colour rendition and uniform flat beam, using a monochromatic light source with a native colour rendering index greater than 90 at a colour temperature of 6000 Kelvin.

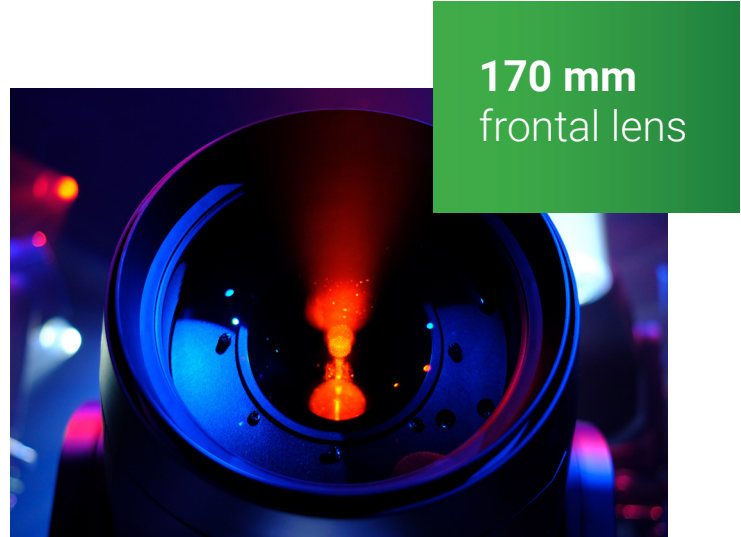

5 Series - Source	Lumens	Native CRI	Front Lens	Weight
650 W - 6700 K	32,000	greater than 90	170 mm	32.9 Kg
Eurus-S	Eurus-S	Eurus-TC		

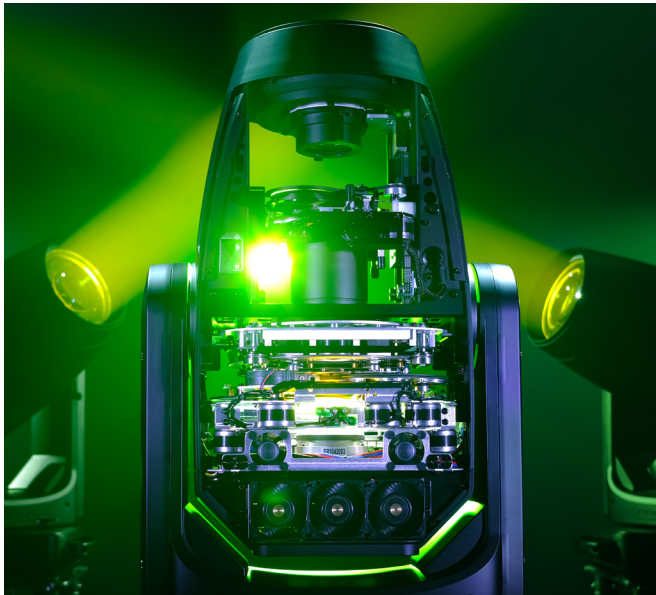

Eurus focuses on what's essential... versatility!

Feature-rich from the factory, Eurus includes a subtractive CMY colour mixing system combined with a variable CTO and a seven-position complementary colour wheel for displaying an infinite palette of vivid pastels and saturated colours.

In addition, the colour section contains two additional filters for optimising the colour rendering index and TM30 readings. The framing section allows accurate positioning of each shutter blade on a 100% surface area in all positions, so that the user can frame any object regardless of the luminaire's position.



And that's not all

The image section includes 18 interchangeable HD glass gobos on two wheels: one rotating wheel with seven positions and one fixed wheel with eleven positions. The effects section includes one continuous dynamic effect-wheel and a 15-blade iris diaphragm. Additional standard features in Eurus include: light and heavy frost filters; a prism effect system comprising two combinable and indexable rotating prisms with fixed and rotating gobos that can create unusual and spectacular kaleidoscopic effects; a strobe effect, with speed adjustment; an electronic dimmer allowing perfect light adjustment from 0 to 100% without colour variation.

Eurus has a highly efficient phase-change liquid cooling system using a heat pipe that includes a particularly effective ultra-silent ventilation mode, designed for stage and studio applications.



**It offers the versatility
and freedom you need to
express yourself**

**Ayrton, once again, is setting
new requirement standards.**

Eurus will demand no compromises. It offers the versatility and freedom you need to express yourself. An aesthetic, compact, state-of-the-art machine with capabilities you can truly appreciate.

Elegant... Efficient... Versatile...

Eurus caters to lighting designers looking for a profile luminaire with incredible adaptability.

In the pursuit of the essential, Ayrton continues to lead the way.

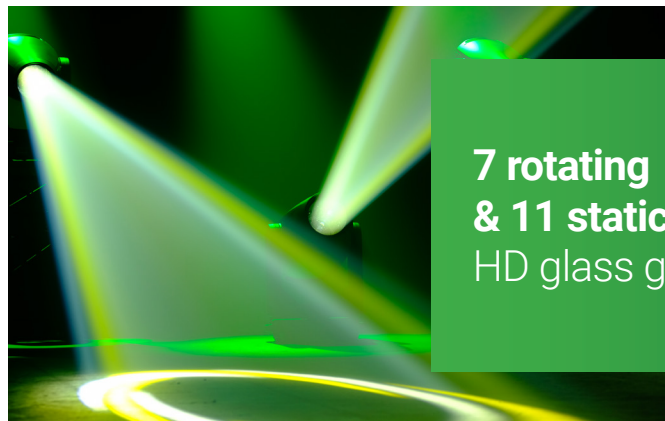

**7 rotating
& 11 static
HD glass gobos**

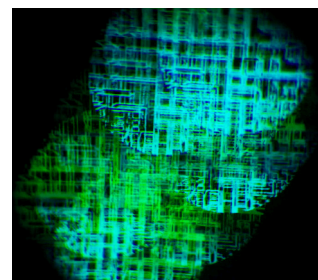
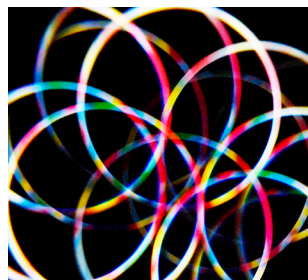
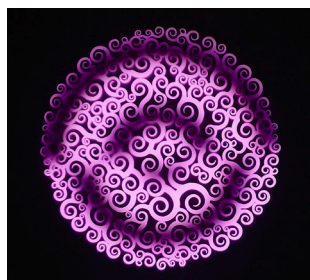
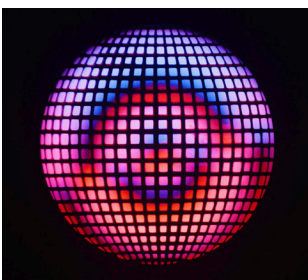

Colours

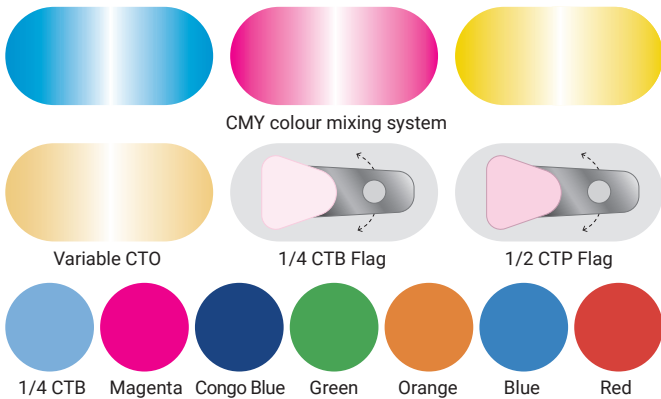

Gobos

Gobos Ø 27 mm | Image Ø 22 mm



Framing system

Iris diaphragm

Frost filters

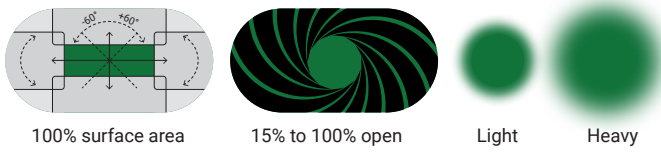

Effects wheel

Prisms



Dimmer

Strobe



Photometry

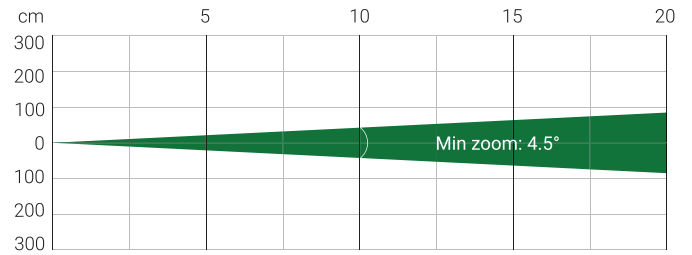

Distance (m)	5		10		15		20	
Unit	lux	Ø	lux	Ø	lux	Ø	lux	Ø
Eurus-S	115,900	0.39	29,000	0.79	12,900	1.18	7,250	1.57
Eurus-TC	65,000		16,200		7,200		4,050	

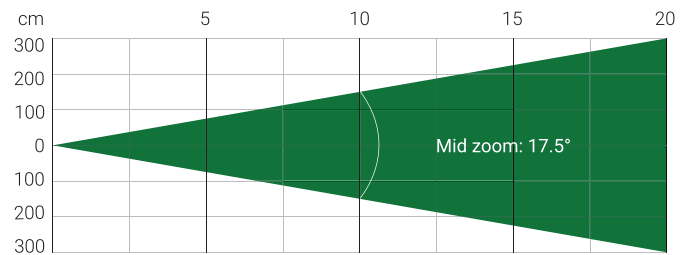

Distance (m)	5		10		15		20	
Unit	lux	Ø	lux	Ø	lux	Ø	lux	Ø
Eurus-S	19,100	1.54	4,780	3.08	2,120	4.62	1,190	6.16
Eurus-TC	10,700		2,680		1,190		670	

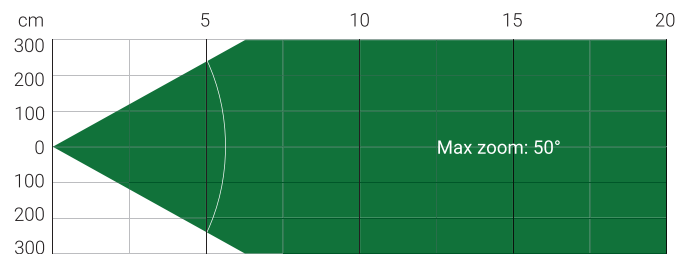

Distance (m)	5		10		15		20	
Unit	lux	Ø	lux	Ø	lux	Ø	lux	Ø
Eurus-S	2,400	4.66	600	9.33	270	13.99	150	18.65
Eurus-TC	1,350		340		150		85	

Version	Eurus-S	Eurus-TC
Total Flux (Integrating sphere)	32,000 lm (zoom at 128%)	22,200 lm (zoom at 128%)
CCT LED Source	8200 (±400 K)	7000 (±400 K)
CCT Luminaire	6700 (±400 K)	6000 (±400K)
Ra Luminaire	70 (Ra: 70±2)	90 (Ra: 90±2)
TLCI	48	89
TM-30	Rf: 72 Rg: 92	Rf: 88 Rg: 97

Fan Mode (Noise Level)	Eurus-S	Eurus-TC
Auto Mode: 45.6 dBA	31,700 lm	22,200 lm
Stage Mode: 49.5 dBA	32,100 lm	23,000 lm
Silence Mode: 39.7 dBA	22,900 lm	16,200 lm
Super Silence: 34.3 dBA	17,300 lm	11,900 lm

Note: noise measured at 1m distance, static status, ambient 31dBA

OPTICS

- 13 elements 11:1 zoom high-resolution optic system
- Beam aperture: 4.5° to 50°
- Fast motorised linear zoom
- Tempered anti-reflective coated lenses
- 170 mm frontal lens for greater performance

LIGHT SOURCE

EURUS-S:

- 45,600 lumens 8000 K white light engine
- Total luminaire output: up to 32,000 lumens
- Colour temperature output: 6700 K
- CRI: greater than 70

EURUS-TC:

- 32,000 lumens 7000 K white light engine
- Total luminaire output: up to 22,200 lumens
- Colour temperature output: 6000 K
- CRI: greater than 90

EURUS-S & EURUS-TC:

- Rated life (L70): up to 40,000 hours
- Flicker-free source management suitable for TV applications and all video-recorded events

MOVEMENT

- Extremely accurate positioning
- Moving-head operated via either 8- or 16-bit resolution
- High-resolution stepper motors operated via microprocessors to ensure extreme accuracy and smooth movement
- Pan and tilt automatic repositioning
- Moving head range: 540° (pan), 270° (tilt)

COLOURS

- Sophisticated colour mix system providing CMY colour mixing
- Variable CTO colour temperature correction
- Fixed colour wheel with seven complementary colours
- 2 CRI improvement filters

GOBOS

- Indexable rotating gobo wheels with 7 high-precision glass gobos, plus open position
- Adjustable-speed rotating gobo in both directions
- Fixed gobo wheel with 11 high-precision glass gobos, plus open position
- Gobo diameter: 27.0 mm
- Image diameter: 22.0 mm
- Gobo thickness: 1.1 mm

FRAMING SYSTEM

- 4 individually positionable shutter blades on a 100% surface area in all positions
- Rotation of the framing system module: +/- 60°

IRIS DIAPHRAGM

- Fast iris diaphragm with adjustable dynamic effects
- Iris range: 15% to 100% open

FROST

- 2 frost filters: one light, one heavy

EFFECTS

- Focusable graphic animation effect-wheel with continuous rotation in both directions
- 2 combinable rotating and indexable prisms: one 5-facet circular, one 4-facet linear

DIMMER / STROBE

- Electronic dimmer, allowing perfect light adjustment from 0 to 100% without colour variation
- Strobe effect, with speed adjustment from 1 to 25 flashes per second

SOFTWARE FEATURES

- Local DMX addressing of luminaire and optional parameters through its built-in LCD control panel
- Remote DMX addressing of luminaire and optional parameters through a standard RDM DMX controller
- Information menu including hour counter, temperature, software version

HARDWARE FEATURES

- Graphic LCD display for addressing and special functions settings, with flip function
- Clicking jog wheel to set functions
- Excess temperature protection
- Integrated wireless CRMX TiMo™ RDM receiver from LumenRadio™
- XLR 5-pin male and female connectors for DMX connection
- Ethercon RJ45 IN / OUT connectors for ArtNet™ connection
- PowerCON TRUE1 male connector for power connection

CONTROL

- DMX 512 protocol, through DMX cable or a wireless system
- DMX-RDM compatible
- Stand-alone mode and Master/Slave modes
- ArtNet™ & sACN protocol through Ethernet cable
- Local control panel, with LCD display
- Choice of 3 DMX modes (from 39 to 62 DMX channels)

POWER SUPPLY

- Electronic supply with active PFC
- 100 to 240 Volts – 50/60Hz
- Power: 1,000 W maximum

COOLING SYSTEM

- Advanced liquid cooling system
- Self-adjusting variable speed fans for quiet operation (Auto mode)
- Selectable ventilation user modes with a new Silent Mode
- Safety protection against temperature excesses

HOUSING

- Moving-head skeleton made of aluminium and steel metal plates
- Base in die-cast aluminium
- Heatsinks in aluminium and copper
- Moulded covers in self-extinguishing fire retardant ABS PC (V0 class)
- Two-side handles for transportation
- Four heavy-duty feet for better stability
- IP20 protection rating
- Exterior finish: black (Carbon)

INSTALLATION

- Fastening bracket system: two Omega ¼ turn brackets designed for use with standard clamps
- Mounting points: four ¼ turn locking fittings allowing installation of Omega brackets on luminaire
- Safety cable attachment point

OPERATING PARAMETERS

- Operating positions: all (device on floor or fixed to a support)
- Maximum permitted ambient temperature (Ta max): 45° C (113° F)
- Minimum permitted ambient temperature (Ta min): -10° C (14° F)
- Minimum usage distance: 2.0 m (6.56 ft)

COMPLIANCE

EU (EMC & LVD):

- EMC Directive 2014/30/EU
- LVD Directive 2014/35/EU

US (Safety & LVD):

- UL 1573
- FCC Part 15, Subpart B: 2018

SIZE

- Product: 445 x 743 x 273 mm (l x h x d)
- Flight-case foam: 655 x 590 x 555 mm (l x h x d)

WEIGHT

- Product: 32.9 KG

PRODUCT CODES

- 011540: EURUS-S – CLASSICAL 5 SERIES
- 011545: EURUS-TC – CLASSICAL 5 SERIES

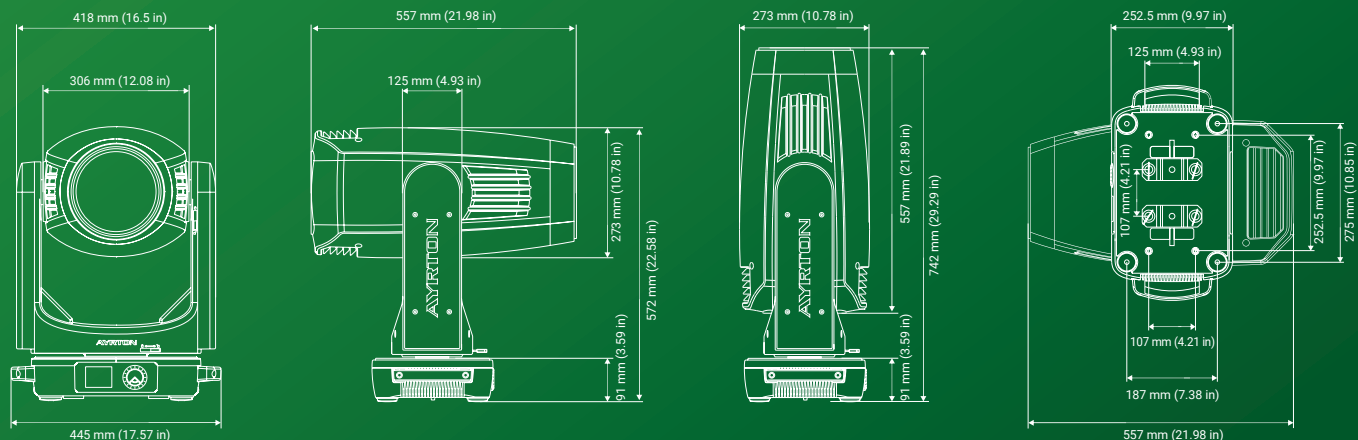



AYRTON

Digital Lighting

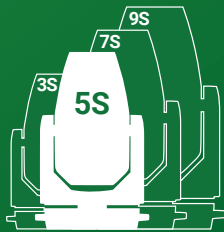

www.ayrton.eu

12.2020